

Spence Type E Main Valve



Figure 1. Type ED Valve

Introduction

The Type E Main Valve is pilot-operated normally closed, single seat design featuring packless construction, balanced metal, diaphragms and protected main spring.

One or more pilot regulators are mounted to Type E main valve to fit with the specifications defined by the pressure regulating system.

Features

- Normally Closed
- Single Seat
- Balanced Metal Diaphragms
- Protected Main Spring
- Fluid, Gas and Vapor Applications
- Multiple Trims for Precise Sizing
- ANSI/FCI 70-2 Class IV Shutoff
- ANSI/FCI 70-3 Class VI Shutoff available with composition disk
- Easy In-line Maintenance
- Wide Variety of Pilots for Many Applications
- Minimum Differential Pressure - 10 psi / 0.7 bar

Type E

Specifications

This section lists the specifications for the Type E main valve. Factory specifications are stamped on the nameplate fastened on the regulator at the factory.

<p>Typical Configurations Type ED: Pressure Reducing Type EA: Air Adjusted Type EQ: Back Pressure Type EMD: Solenoid Controlled Type EM: Solenoid Actuated Type EN: Differential Type ET: Temperature Control</p> <p>Valve Sizes NPS 3/8, 1/2, 3/4, 1, 1-1/4, 1-1/2, 2, 2-1/2, 3, 4, 5, 6, 8, 10 and 12 / DN 10, 15, 20, 25, 32, 40, 50, 65, 80, 100, 125, 150, 200, 250 and 300</p> <p>End Connection Styles NPT, CL125, CL150, CL250, CL300, CL600</p> <p>Pressure Rating⁽¹⁾ See Table 1</p>	<p>Temperature Rating⁽¹⁾ See Table 1</p> <p>Rated Flow Coefficient See Table 2</p> <p>Main Valve Material Cast iron and Cast steel</p> <p>Approximate Weight See Table 4</p> <p>Options Composition Disk Parabolic Disk Balanced Construction Integral Mount Pilot InsulCap[®] Insulating Jacket Secoweld High Temperature Construction Dashpot Low dP (LP) Main Spring EZ Connections</p>
--	---

1. The pressure/temperature limits in this Bulletin and any applicable standard or code limitation should not be exceeded.

Table 1. Type E Main Valve Pressure and Temperature Rating⁽¹⁾

MAIN VALVE MATERIAL	END CONNECTION	PRESSURE RATING		TEMPERATURE RATING	
		psig	bar	°F	°C
Cast iron	250 NPT	250	17.2	406	207
	CL125	125	8.62	450	232
	CL250	250	17.2	450	232
Cast steel	300 NPT	300	20.7	600	315
	CL150	150	10.3	500	260
	CL300	300	20.7	600	315
	CL600	600	41.4	600	315

1. Ratings based on maximum inlet conditions.

Table 2. Type E Main Valve Rated Flow Coefficients

SEAT FACTOR	VALVE SIZE, NPS / DN														
	3/8 / 10	1/2 / 15	3/4 / 20	1 / 25	1-1/4 / 32	1-1/2 / 40	2 / 50	2-1/2 / 65	3 / 80	4 / 100	5 / 125	6 / 150	8 / 200	10 / 250	12 / 300
Full	1.5	2.8	5.4	8.8	14.1	19.8	31	44	74	109	169	248	444	706	1113
Full 75%	----	2.1	4.0	6.6	10.6	14.8	23.3	33	56	82	127	186	333	530	835
Full 50%	----	1.4	2.7	4.4	7.0	9.9	15.5	22	37	55	85	124	222	353	557
Normal	0.65	1.5	4.8	7.5	10.4	14.6	17.6	24	43	78	115	151	249	377	631
Normal 75%	----	----	----	----	----	----	----	18	33	59	87	114	187	283	474
Normal 50%	----	----	----	----	----	----	----	12	22	39	58	76	125	189	316

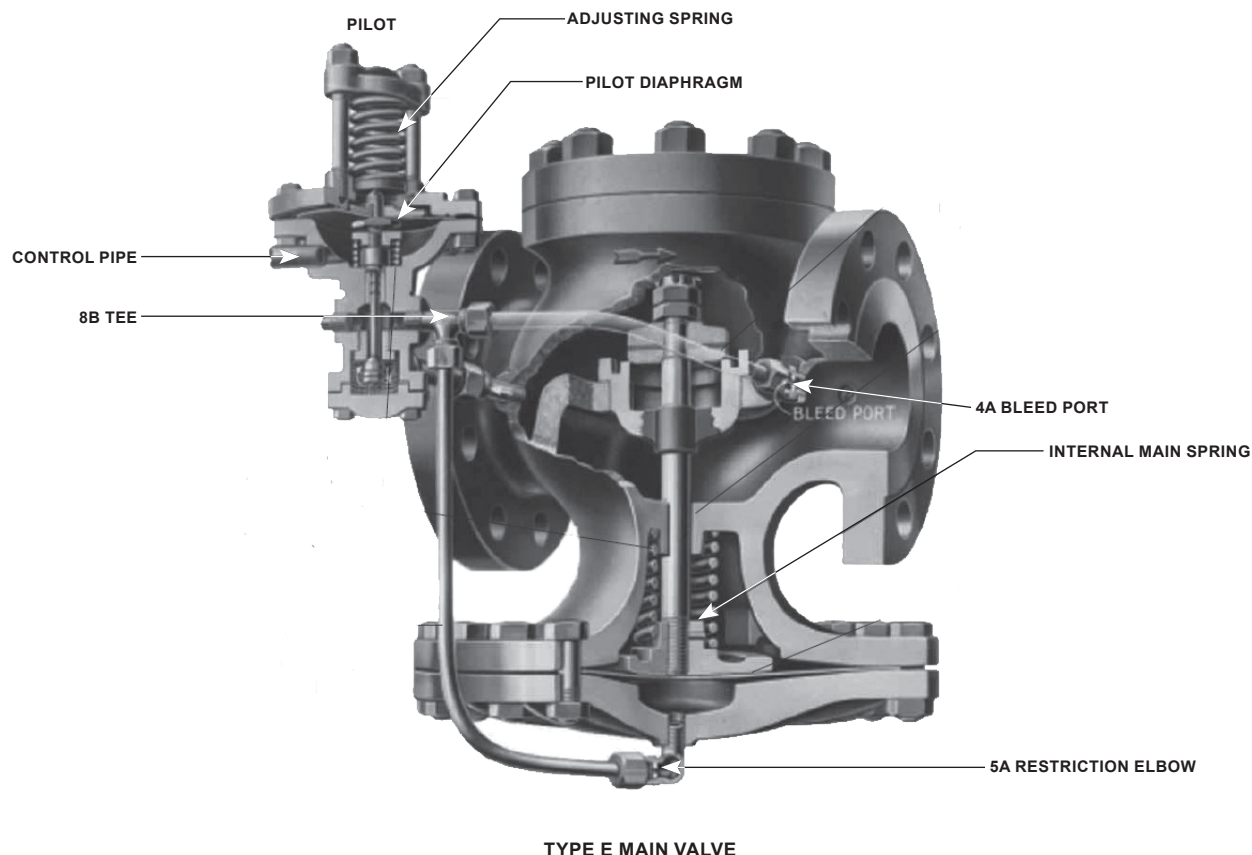

Figure 2. Type E Main Valve Operational Schematic

Principle of Operation

The regulator is operated by initial steam or fluid pressure. It is normally closed, being held so by initial pressure on the disk and by an internal main spring. See Figure 2. When the pilot is opened (see pilot instructions), initial pressure flows through the pilot to the 8B tee. 4A bleed port restricts the flow and pressure builds under the diaphragm and opens the main valve. The 5A restriction elbow steadies the operation of the regulator.

Delivery pressure feeds back through the control pipe to the pilot diaphragm. As this pressure approaches a balance with the thrust of the adjusting spring, the pilot throttles the loading pressure. In turn, the main valve takes a position established by the loading pressure where just enough steam flows to maintain the set delivery pressure.

Installation

Planning

- Locate the valve in a straight run of horizontal pipe.
- Allow headroom above the valve for access through the blind flange.
- Provide clearance for stem withdrawal underneath.
- Prevent water hammer and erratic operation by installing traps to provide proper drainage before and after the valve and before secondary pressure relief valve or control valve.
- Avoid damaging effects of scale and dirt in the pipe lines by using a strainer as shown in Figure 3.

Type E

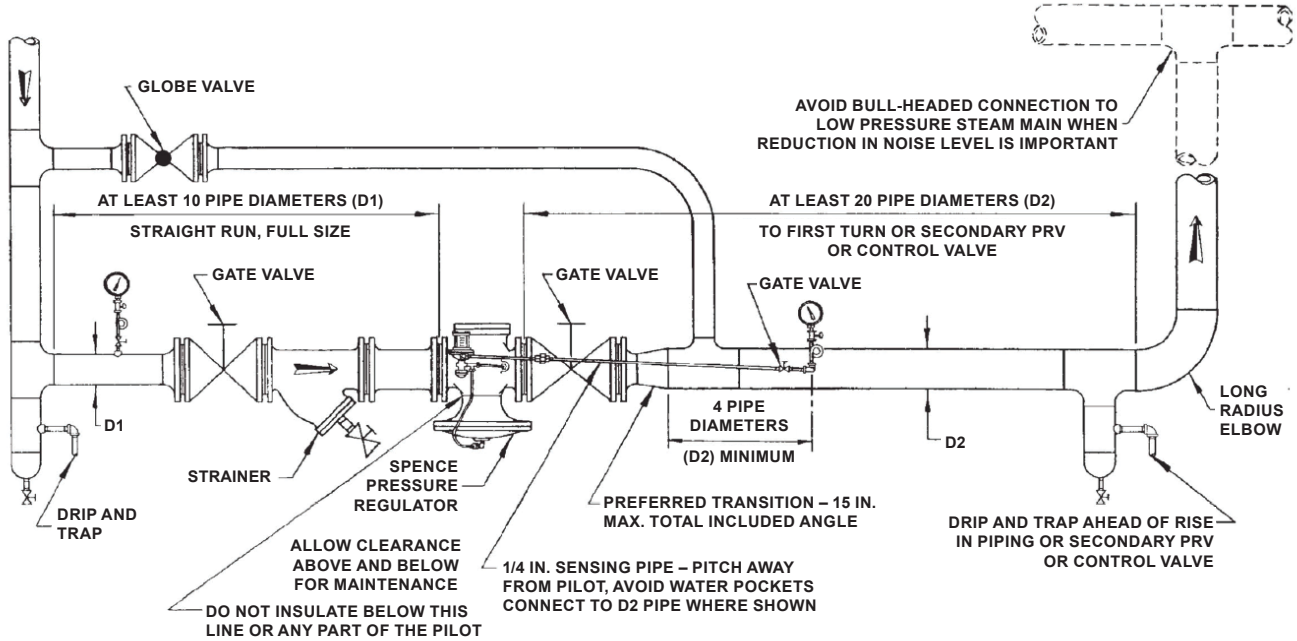

TYPICAL INSTALLATION

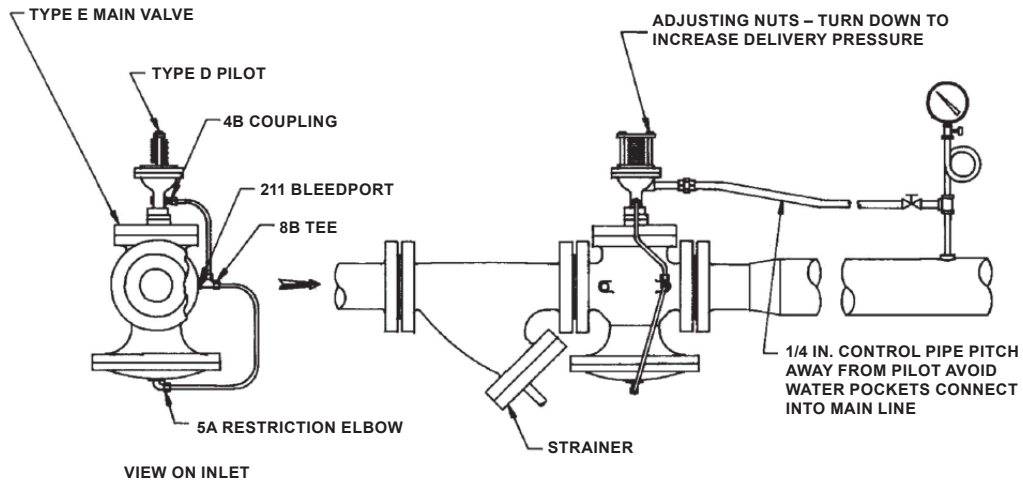

INSTALLATION OF INTEGRALLY MOUNTED PILOT

Figure 3. Type E Main Valve Installation

- Provide a three-valve by-pass to facilitate inspection without interrupting service.
- To eliminate excessive noise and erratic regulation with steam and other compressible fluids, enlarge the delivery pipe size to effect a reasonable flow velocity at the reduced pressure. A tapered transition is recommended.
- If possible, avoid a sharp turn close to the regulator outlet and a bull-headed tee connection to the low pressure main.
- Install initial and delivery pressure gauges to indicate performance.
- If the pressure rating of the delivery system or connected equipment is less than the initial steam pressure, provide a safety valve.

Main Valve

- Flush the piping system thoroughly to clear it of welding beads, scale, sand, etc.
- Mount the main valve with diaphragm chamber down and arrow on body pointing in the direction of flow. Screwed end valves should be mounted in unions.

Pilot

For Side Mount Construction

1. Mount the pilot on either side of the main valve by means of 1/4 in. / 6.35 mm nipple and union provided.
2. Make this connection on the 1/4 in. / 6.35 mm pipe tap at the inlet of the main valve as shown in Figure 4.

For Integral Mount Construction

1. Remove blind flange on pilot and mount on blind flange of main valve using provided bolt.
2. Screw 4A bleed port fitting into the 1/8 in. / 3.18 mm pipe tap at the outlet of the main valve body. Note bleed orifice in this fitting is vital to operation of regulator.

Note

As a general rule of thumb, tighten 1.5 to 3 turns past hand tight all NPT connection and use thread sealant with a temperature range up to 450°F / 232°C.

3. Screw 8B tee into 1/8 in. / 3.18 mm pipe tap in pilot. Select tap facing downstream.
4. Screw 5A restriction elbow containing restriction orifice into 1/8 in. / 3.18 mm pipe tap on the underside of main valve diaphragm chamber. If the initial pressure or pressure drop is less than 15 psi / 1.03 bar, use 5B open elbow.
5. Connect tubing bends as illustrated in Figure 4. Valves with condensation chamber are fitted up according to Figure 4.

Control Pipe

1. Use 1/4 in. / 6.35 mm pipe for this line which connect the pilot diaphragm chamber to the desired point of pressure control.
2. Take the control at a point of minimum turbulence. Avoid control immediately at the valve outlet or after a turn.
3. When the delivery pipe expands in size, select a spot at least 4 pipe diameters beyond the point of enlargement.
4. Pitch away from pilot to avoid erratic operation and excessive fouling.
5. Eliminate water pockets.
6. Locate delivery pressure gage in control pipe to show pressure actually reaching pilot diaphragm.

Type E

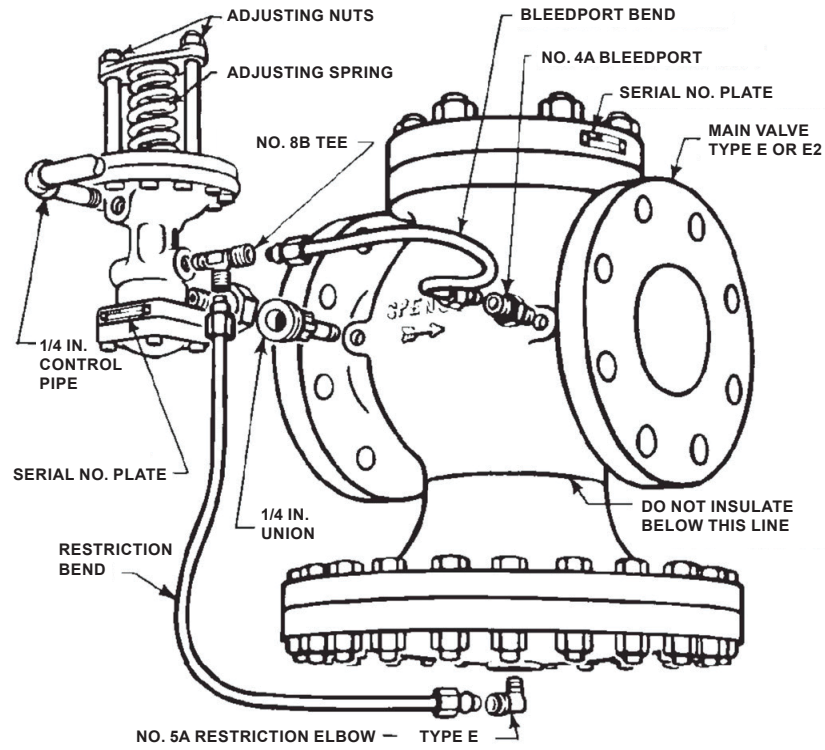

Figure 4. Mounting Pilot on Type E Main Valve

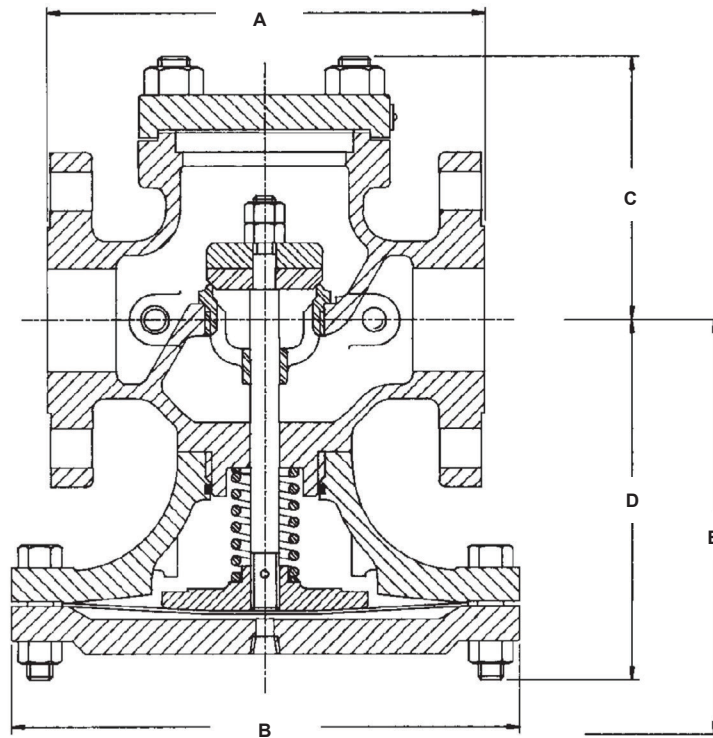

Figure 5. Type E Main Valve Dimension

Table 3. Type E Main Valve Dimension

VALVE SIZE		FACE TO FACE DIMENSIONS - A										B		C				D		E	
		NPT		CL 125 and CL150		CL 250		CL300		CL600		In.	mm	All Except CL600		CL600		In.	mm	In.	mm
		In.	mm	In.	mm	In.	mm	In.	mm	In.	mm			In.	mm						
3/8	10	4-3/8	111	----	----	----	----	----	----	----	5-7/8	149	2-3/4	70	----	----	5-1/4	133	7-3/8	187	
1/2	15	4-3/8	111	----	----	----	----	----	----	6	152	5-7/8	149	2-3/4	70	2-3/4	70	5-1/4	133	7-3/8	187
3/4	20	4-3/8	111	----	----	----	----	----	----	6-3/8	162	6-1/2	165	2-7/8	73	3-7/8	98	5-1/2	140	7-7/8	200
1	25	5-3/8	137	5-1/2	140	6	152	6-1/2	165	6-1/2	165	7	178	3-5/8	92	4-1/4	108	6-1/4	159	8-7/8	225
1-1/4	32	6-1/2	165	6-3/4	171	7-1/4	184	7-7/8	200	7-7/8	200	7-7/8	200	4-1/8	105	4-5/8	117	6-1/2	165	9-1/8	232
1-1/2	40	7-1/4	184	6-7/8	175	7-3/8	187	8	203	8	203	8-3/4	222	4-3/8	111	5-1/8	130	7-1/8	181	9-3/4	248
2	50	7-1/2	191	8-1/2	216	9	229	10-1/4	260	10-1/4	260	9-7/8	251	5-1/4	133	5-3/4	146	7-5/8	194	11-1/4	286
2-1/2	65	----	----	9-3/8	238	10	254	11-1/4	286	11-1/4	286	10-7/8	276	5-3/4	146	7-7/8	200	8-3/8	213	12-1/8	308
3	80	----	----	10	254	10-3/4	273	12-1/4	311	12-1/4	311	11-3/4	298	6-5/8	168	9-1/8	232	9-1/4	235	14-5/8	371
4	100	----	----	11-7/8	302	12-1/2	318	12-1/2	318	14-1/2	368	14-3/4	375	7-5/8	194	10-5/8	270	11-7/8	302	18-1/4	464
5	125	----	----	13-5/8	346	14-1/2	368	14-1/2	368	16-1/2	419	16-7/8	429	8-1/2	216	12-1/2	318	12-1/2	318	20-1/8	511
6	150	----	----	15-1/8	384	16	406	16	406	17-3/8	441	19-3/4	502	10	254	13-3/4	349	14-1/8	359	22-3/8	568
8	200	----	----	19	483	20	508	20	508	21-5/8	549	22-1/2	572	11-1/2	292	15-3/8	391	17-1/4	438	27-3/4	705
10	250	----	----	23-5/8	600	25	635	25	635	----	----	28	711	13-3/4	349	----	----	23-3/8	594	36-1/4	921
12	300	----	----	26-1/2	673	28	711	28	711	----	----	33	838	15-7/8	403	----	----	25-1/4	641	41-1/2	1054

Table 4. Type E Main Valve Approximate Weight

VALVE SIZE		END CONNECTION STYLE											
		NPT		CL125		CL150		CL250		CL300		CL600	
NPS	DN	lbs	kg	lbs	kg	lbs	kg	lbs	kg	lbs	kg	lbs	kg
3/8	10	14	6.35	----	----	----	----	----	----	----	----	----	----
1/2	15	14	6.35	----	----	----	----	----	----	----	----	20	9.07
3/4	20	18	8.16	----	----	----	----	----	----	----	----	28	12.7
1	25	23	10.4	24	10.9	26	11.8	27	12.2	31	14.1	32	14.5
1-1/4	32	33	15.0	36	16.3	37	16.8	40	18.1	41	18.6	45	20.4
1-1/2	40	43	19.5	45	20.4	47	21.3	51	23.1	55	24.9	58	26.3
2	50	62	28.1	67	30.4	73	33.1	72	32.7	78	35.4	83	37.6
2-1/2	65	----	----	82	37.2	95	43.1	100	45.4	100	45.4	130	59.0
3	80	----	----	110	49.9	125	56.7	130	59.0	140	63.5	175	79.4
4	100	----	----	200	90.7	210	95.3	235	107	230	104	310	141
5	125	----	----	280	127	295	134	315	143	310	141	490	222
6	150	----	----	385	175	420	191	455	206	470	213	655	297
8	200	----	----	657	298	700	318	735	333	710	322	1070	485
10	250	----	----	1260	572	1240	562	1430	649	1300	590	----	----
12	300	----	----	2070	939	2060	934	2145	973	2140	971	----	----

Type E

Ordering Information

When ordering, complete the ordering guide on this page. Refer to the Specifications section on page 2.

Review the description to the right of each specification and the information in each referenced table or figure. Specify your choice whenever a selection is offered.

Ordering Guide

Body Size (Select One)

- NPS 3/8 / DN 10
- NPS 1/2 / DN 15
- NPS 3/4 / DN 20
- NPS 1 / DN 25
- NPS 1-1/4 / DN 32
- NPS 1-1/2 / DN 40
- NPS 2 / DN 50
- NPS 2-1/2 / DN 65
- NPS 3 / DN 80
- NPS 4 / DN 100
- NPS 5 / DN 125
- NPS 6 / DN 150
- NPS 8 / DN 200
- NPS 10 / DN 250
- NPS 12 / DN 300

Main Valve Material (Select One)

- Cast iron
- Cast steel

Option

- Composition Disk
- Parabolic Disk
- Balanced Construction
- Integral Mount Pilot
- InsulCap® Insulating Jacket
- Secoweld
- High Temperature Construction
- Dashpot
- Low dP (LP) Main Spring
- EZ Connections

End Connection Style (Select One)

- NPT
- CL125
- CL150
- CL250
- CL300
- CL600

 SpenceValve.com

Americas

McKinney, Texas 75070 USA
T +1 800 558 5853
+1 972 548 3574

Europe

Bologna 40013, Italy
T +39 051 419 0611

Asia Pacific

Singapore 128461, Singapore
T +65 6777 8211

Middle East and Africa

Dubai, United Arab Emirates
T +971 4 811 8100

VCBUL-15903 © 2021 Emerson Electric Co. All rights reserved. 11/21
Spence is a mark owned by one of the companies in the Emerson Automation Solutions business unit of Emerson Electric Co. The Emerson logo is a trademark and service mark of Emerson Electric Co. All other marks are property of their prospective owners.

The contents of this publication are presented for informational purposes only, and while every effort has been made to ensure their accuracy, they are not to be construed as warranties or guarantees, express or implied, regarding the products or services described herein or their use or applicability. All sales are governed by our terms and conditions, which are available upon request. We reserve the right to modify or improve the designs or specifications of such products at any time without notice.

Emerson Electric Co. does not assume responsibility for the selection, use or maintenance of any product. Responsibility for proper selection, use and maintenance of any Emerson Electric Co. product remains solely with the purchaser.