

August 2022

Description

ECT DIN-style signal isolators, converters, repeaters, boosters and splitters feature solid metal housings that stand up to the continuous, daily rigors of process control and factory automation applications.

Rugged and reliable, the ECT is available in 2-wire Output Loop powered model in a narrow 15mm housing, 2-wire Input-Loop powered model, and 4-wire (line/mains) powered models. The complete family delivers economical solutions for an expansive range of signal interface applications.

- **Isolate Signals** to stop erratic measurements caused by ground loops.
- **Convert Signals** so field instruments can interface directly with an indicator, recorder, DCS, PLC or PC-based SCADA system.
- **Split One Signal** to allow one primary measurement to be sent to two separate systems.
- **Get two isolators in one.** The ECT is available in dual channel I/O models that provide application flexibility while reducing space requirements and costs.
- **Protect Equipment and Signals (Area Isolation)** by eliminating common electrical paths.
- **Amplify (Boost) Signals** so that more instruments can be added to an overburdened loop.
- **Solve “Bucking” Power Supplies** by stopping a conflict caused by a 4-wire transmitter and a DCS both trying to power the same process loop.
- **Step Down Dangerous,** high voltage signals to safer levels to protect plant personnel.
- **Solve DCS Start-Up Problems** caused by non-isolated transmitters by installing an ECT in each troublesome loop.

To choose the right ECT for your application, determine the power supply type by reviewing installation examples:

POWER SUPPLY TYPE	PAGE
2-Wire, Output-Loop Powered (12-42Vdc)	2-3
2-Wire, Input-Loop Powered (5.5Vlp)	3
4-Wire, Line/Mains Powered (117Vac, 230Vac, 24Vdc)	6



Featuring metal DIN-style housings in widths starting at 15mm, the ECT snaps securely onto standard G-type and Top Hat rails.

Features

- **Current and voltage inputs.** Available models handle Current and Voltage Signals.
- **2-wire (loop) and 4-wire (line/mains) powered.** Versatile choices allow you to match the ECT to the type of AC or DC power available at each location.
- **Narrow 15mm housing.** New thinner width lets you get more isolators in the same small space, without sacrificing RFI/EMI protection and -40 to 85C operating temperature range you need for more extreme locations.
- **Superior signal isolation (up to 1500Vrms).** Industrial-strength protection stops ground loops, motor noise, and other electrical interferences from affecting process signals.
- **RFI/EMI protection.** The ECT provides an effective barrier against the unpredictable, harmful effects of radio frequency and electromagnetic interference. When ordered with the -RF option, the ECT delivers enhanced protection for especially noisy environments.

Certifications



Underwriter’s Laboratories: Ordinary (non-hazardous) or Hazardous Locations* Class I, Division 2, Groups A, B, C & D T4



CE: Conformant to EMC Directive 2014/30/EU EN 61326; Low Voltage Directive 2014/35/EU EN 61010

*Certification not applicable to ECT-DIN models equipped with the -RF option or 4-wire, line/mains powered, dual input channels.

ECT-DIN

Signal Isolator, Converter,
Repeater, Booster and Splitter

2- Wire, Output-Loop Powered Models

This ECT model derives operating power from its output side where loop power is typically made available by the receiving device, such as a DCS.

Narrow 15mm housing

A narrow, 15mm wide housing model is available with 4-20mA, 1-5V and 0-10V input and 4-20mA output, allowing you to fit more isolators in the same available space. With the rugged RF/EMI protection and -40C to 85C operating temperature range you expect from Moore Industries products, this isolator doesn't require installation in climate controlled environments, making it perfect for more extreme locations.

Stop Ground Loop Noise

Differences in potential between a grounded transmitter and a grounded receiving device may result in unpredictable ground loop problems, which can lead to signal drift. Use the ECT to break the galvanic path between the field instrument and receiving device (Figure 1).

Convert Signals

The ECT takes one process signal type (such as 1-5V) and convert it to a standard, isolated 4-20mA, allowing devices with incompatible signal types to interface with one another (Figure 1).

Divert and Protect (Area Isolation) Signals

Using the ECT, you can send the output from one transmitter to a second location; protect expensive monitoring/control equipment by eliminating common electrical paths; or create a buffer between devices to allow interruption of one leg of a loop without impacting the other (Figure 2).

Amplify (Boost) Signals

If you need to add an instrument to an overloaded loop, use the ECT. It features a high drive capability of 600 ohms (with a 24V power supply) and a low input impedance of just 50 ohms (Figure 3).

Solve "Bucking" Power Supplies

When two devices (such as a 4-wire transmitter and a DCS) are trying to source power to the same loop, the result is a non-functioning loop. When neither of the devices can be eliminated, the solution is a 2-wire ECT. It can operate with powered inputs from both sides, restoring normal operations to the loop (Figure 4).

Figure 1. Input/output loop isolation and signal conversion.

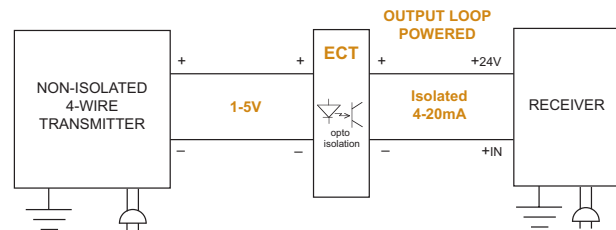

Figure 2. Divert a process signal, or protect expensive equipment by eliminating a common electrical path.

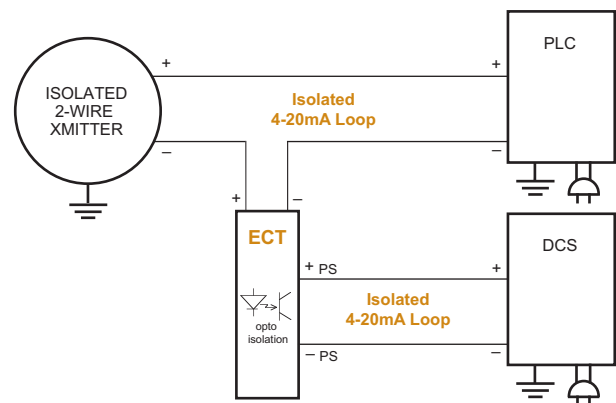

Figure 3. Boost process signals to allow another instrument to be added to an otherwise overloaded loop.

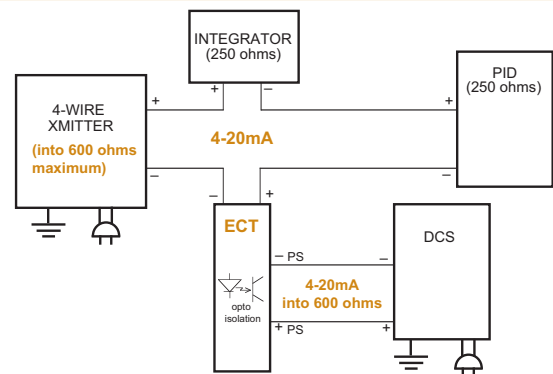
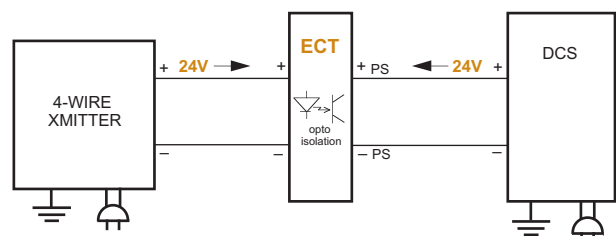

Figure 4. Restore a loop experiencing "bucking" power supplies to normal operation.



ECT-DIN

Signal Isolator, Converter,
Repeater, Booster and Splitter

Step Down Unsafe High Level Signals

To protect plant personnel, the ECT comes with an optional external input transformer (-EM option) to step down high level AC current inputs to a low level signal. This permits safer servicing without opening the secondary of a current transformer (Figure 5).

2-Wire, Input-Loop Powered Models

The 2-wire, input-loop powered ECT derives its operating power from the input side of the process loop (Figure 6). This model provides loop isolation when line power or output-loop power is not available. Its simple hook-up method provides a cost-effective interface between field signals and a computer, DCS or other multiple-input system.

IMPORTANT NOTE: When choosing this type of isolator, notice the total load imposed on the input loop. Because it derives all operating power from the input loop, that loop must be able to handle the isolator's input impedance and output load (maximum output load is 250 ohms).

Single and Multiple Unit Instrument Enclosures

Designed to meet NEMA 4X and IP66 ratings, the R-BOX is the perfect solution for protecting the ECT in field and control room applications. Rugged and versatile, it delivers a high impact structure and resistance to ultraviolet rays and chemicals.

The R-BOX mounts on a pipe, panel or surface, and comes in a variety of widths to economically accommodate just one, or up to 10, ECTs. It features a pre-installed mounting rail; customizable conduit entry options; a clear cover; and a secure locking mechanism.

For more information, see the R-BOX Field-Mount Enclosure for DIN Instruments data sheet.

Figure 5. To protect plant personnel, step down potentially dangerous high level AC current signals to lower level signals.

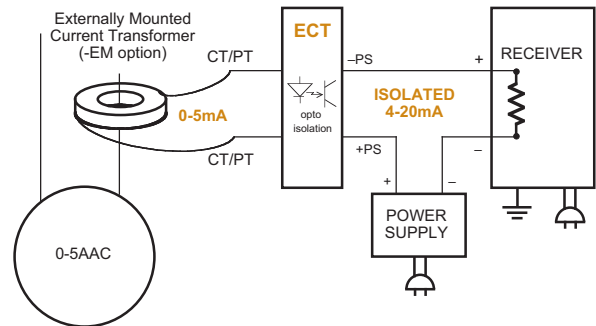

Figure 6. The input-loop powered ECT provides loop isolation when line power or output-loop power is not available.

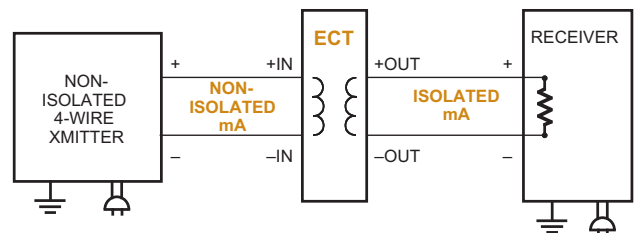
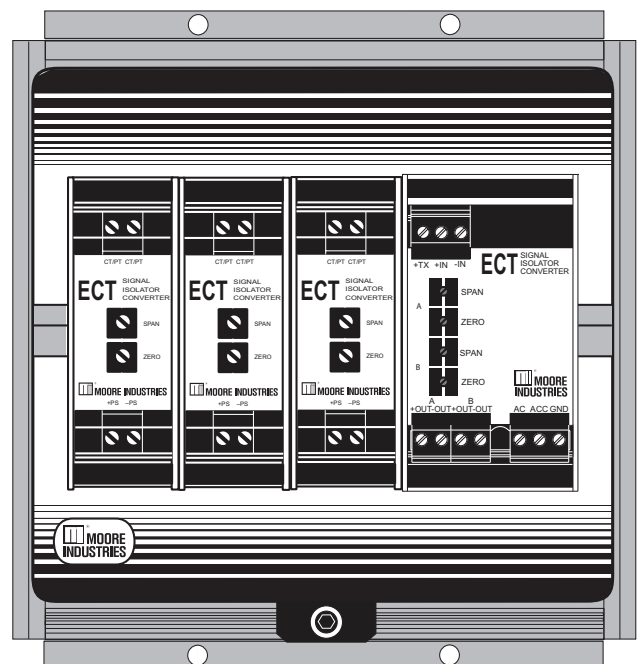

Figure 7. Available in a variety of widths, our R-BOX field-mount instrument enclosure is designed to protect DIN-rail instruments in even the most rugged environments.



ECT-DIN

Signal Isolator, Converter,
Repeater, Booster and Splitter

► Specifications for 2-Wire Output-Loop Powered Models

<p>Performance</p> <p>Accuracy: ±0.1% of span (±0.2% for 0-150 AC inputs) Stability: ±0.2% of reading per year Isolation: WITHOUT -RF OPTION: 1500Vrms between input and output; WITH -RF OPTION: 500Vrms between input and output Output Response Time: DC Inputs, 100msec to 99% of output maximum; AC Inputs, 400msec to 99% of output Ripple: 10mV peak-to-peak maximum measured across a 250 ohm resistor Over-Voltage Protection: 48V, maximum on output; 48V reverse polarity protection on output Maximum Input Overrange: Current Inputs 250% of full scale; DC Voltage Inputs, 150% of full scale Burdens: 1V maximum with 4-20mA input; 0.01V maximum with 0-5A input Load Capability: $\frac{V_s - 12V_{dc}}{20mA} = \text{ohms}$ Output Current Limiting: 25mA typical; 30mA maximum</p>	<p>Output Tracking: Assuming 4-20mA input and 4-20mA output; the isolator output will follow the input below 3mA when the input fails.</p> <p>Ambient Conditions</p> <p>Operating Range: -40°C to +85°C (-40°F to +185°F)</p> <p>Storage Range: -40°C to +85°C (-40°F to +185°F)</p> <p>Ambient Temperature Effect: ±0.007% of span/°C typical; ±0.015% of span/°C maximum</p> <p>Relative Humidity: 0-95% non-condensing</p>	<p>RFI/EMI Protection: Less than ±0.1% of span error when tested at 10V/m@ 20-1000MHz WITH -RF OPTION: Less than ±0.1% of span error when tested at 20V/m @80-1000MHz, 1kHz AM</p> <p>Common Mode Rejection: Exceeds 95dB@60Hz with a limit of 1500Vrms</p> <p>Adjustments</p> <p>Type: Front panel pots Span: ±10% Zero: ±5% (non-interactive when span is set first)</p> <p>Weight 150g (5.3 oz)</p>
---	---	---

► Ordering Information

UNIT	INPUT	OUTPUT	POWER	OPTIONS	HOUSING
ECT 2-wire (Output-Loop Powered) Isolator/ Converter; Narrow 15mm wide housing	4-20MA into 50 ohms 1-5V into 1 Mohm 0-10V into 1 Mohm	4-20MA into 600 ohms with 24V power supply	12-42DC	-RF Enhanced RFI/EMI filtering provides 20V/m@ 20-1000MHz, 1kHz AM protection with less than ±0.1% of span error -VTD Standard Factory Calibration with NIST Test Data Report	DIN Aluminum 15mm wide DIN-style housing mounts on 32mm G-type (EN50035) and 35mm Top Hat (EN50022) rails FLB2 Externally-mounted flange provides a secure mount and ensures resistance to vibration
ECT 2-wire (Output-Loop Powered) Isolator/ Converter; 25mm wide housing	0-150AC into 100 kohms 0-5AAC into 0.002 ohms	4-20MA into 600 ohms with 24V power supply	12-42DC	-EM Externally-mounted input transformer for current input (available with 0-5Aac input only) -RF Enhanced RFI/EMI filtering provides 30V/m@ 20-1000MHz protection with less than ±0.1% of span error -VTD Standard Factory Calibration with NIST Test Data Report	DIN Aluminum 25mm wide DIN-style housing mounts on 32mm G-type (EN50035) and 35mm Top Hat (EN50022) rails FLB2 Externally-mounted flange provides a secure mount and ensures resistance to vibration

When ordering, specify: Unit / Input / Output / Power / Options [Housing]
Model number example: ECT / 1-5V / 4-20MA / 12-42DC / -RF [DIN]

► Specifications for 2-Wire Input-Loop Powered Models

<p>Performance</p> <p>Accuracy: $\pm 0.075\%$ of span Stability: $\pm 0.2\%$ of reading per year Isolation: 500Vrms between input and output Output Response: 20msec maximum to 99% of output Ripple: 10mV peak-to-peak maximum measured across a 250 ohm resistor Over-Voltage Protection: 48V, maximum on output; 48V, reverse polarity protection on output Maximum Input Overrange: 200% of full scale Burden: 5.5V when outputs are shorted for 4-20mA inputs, 10.5V with 250 ohm load (Output load voltage is reflected on input. Output should be trimmed for anticipated output load) Output Current Limiting: 30mA with 250 ohm output load</p>	<p>Output Tracking: Assuming 4-20mA input and 4-20mA output; the isolator output will follow the input below 3mA when the input fails.</p> <p>Ambient Conditions</p> <p>Operating Range: -40°C to $+85^{\circ}\text{C}$ $(-40^{\circ}\text{F}$ to $+185^{\circ}\text{F})$</p> <p>Storage Range: -40°C to $+85^{\circ}\text{C}$ $(-40^{\circ}\text{F}$ to $+185^{\circ}\text{F})$</p> <p>Ambient Temperature Effect: $\pm 0.018\%$ of span/$^{\circ}\text{C}$; $\pm 0.005\%$ of span/$^{\circ}\text{C}$ gain change</p> <p>Relative Humidity: 0-95% non-condensing</p> <p>Type: Front panel pots Trim: $\pm 1\%$</p>	<p>RFI/EMI Protection: Less than $\pm 0.1\%$ of span error when tested at 10V/m @ 20-1000MHz WITH -RF OPTION: Less than $\pm 0.1\%$ of span error when tested at 30V/m@20-1000MHz</p> <p>Common Mode Rejection: Exceeds 95dB @ 60Hz with a limit of 1500Vrms</p> <p>Adjustments</p> <p>Weight 145g (5 oz)</p>
--	---	--

► Ordering Information

UNIT	INPUT	OUTPUT	POWER	OPTIONS	HOUSING
ECT 2-wire (Input-Loop Powered) Isolator/ Converter	4-20MA into 275 ohms	4-20MA into 0-250 ohms	Current Loop Excitation at 4mA: 5.5VLP 5.5 volts loop powered with 4-20mA (plus voltage across output load)	-RF Enhanced RFI/EMI filtering provides 30V/m @ 20-1000MHz protection with less than $\pm 0.1\%$ of span error -VTD Standard Factory Calibration with NIST Test Data Report	DIN Aluminum DIN-style housing mounts on 32mm G-type (EN50035) and 35mm Top Hat (EN50022) rails FLB2 Externally-mounted flange provides a secure mount and ensures resistance to vibration

When ordering, specify: Unit / Input / Output / Power / Options [Housing]

Model number example: ECT / 4-20MA / 4-20MA / 5.5VLP / -RF [DIN]

Need Enhanced Features?

PC-Programmable Universal Interface

Our model SIY signal isolator, converter, and repeater is the ideal plant standard. This 2-wire (loop-powered), microprocessor-based instrument programs in less than a minute to handle a wide range of current and voltage inputs. It even allows creation of custom input linearization curves. For detailed information, see the SIY data sheet.

Unusual Input and Outputs

We have instruments that handle a wide array of non-standard inputs and outputs.

Custom Signal Isolators

We have engineers on hand to modify our instrument to meet your unique needs.

RTD, T/C, mV, Potentiometer, I/P, P/I, Strain Gage, and Frequency Signals

We are the Interface Solution Experts. When you need to interface field processes with computer-based systems, readout equipment, and other instrumentation... our technology, services, and experience help you do it efficiently, safely, and cost-effectively.

ECT-DIN

Signal Isolator, Converter, Repeater, Booster and Splitter

4-Wire, Line/Mains Powered Models

These ECT models are powered by standard 117Vac, 230Vac, and 24Vdc power supplies (Figure 8). They are designed for applications where line/mains power is readily available, such as the back of a panel or in a control room.

Step Down Unsafe, High Level Signals

To protect plant personnel, the 4-wire ECT comes with an optional external input transformer (-EM option) to step down high level AC current inputs to a low level signal. This permits safer servicing without opening the secondary of a current transformer (Figure 9).

Power a 2-Wire Transmitter

With the -TX option, our 4-wire ECTs provide 24V power to a 2-wire, output-loop powered instrument. This eliminates the need for an additional power supply (Figure 10). **IMPORTANT:** Our 2X4-20MA dual input model provides a transmitter excitation of 16V. Refer to Figure 12 for an illustration of dual input model operation.

“Sharing” or “Splitting” a Process Signal

The ECT with dual outputs will take one input and deliver two identical, completely isolated outputs to two separate monitoring or control devices (Figure 11). This is valuable for viewing one process variable at two locations, such as in custody transfer, where two parties require identical information for accountability or billing purposes. Maintenance of one system does not disturb the information being collected at the second location. In addition, a failure at one receiver will not affect the second loop.

One Isolator Does the Work of Two

When ordered with dual input and output channels, the ECT will perform the functions of two isolators (Figure 12). Each of the ECT’s two input-to-output channels is independent and completely isolated from the other.

Figure 8. 4-wire ECT models are ideal for use where line (mains) power is readily available.

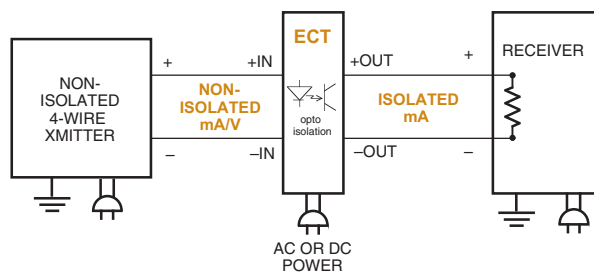

Figure 9. When ordered with the -EM option, the ECT comes with an externally-mounted AC current transformer to “step down” high level signals.

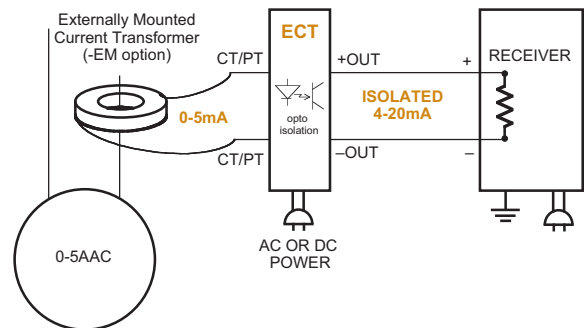

Figure 10. With the -TX Transmitter Excitation option, the ECT will supply loop power to a 2-wire transmitter.

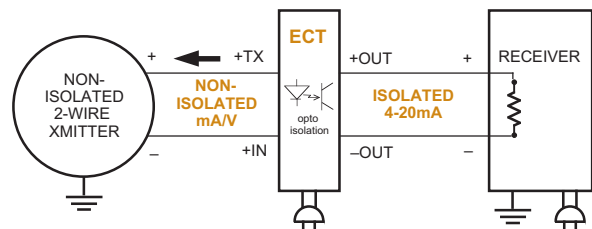

Figure 11. The ECT takes one process input and delivers two completely isolated signal outputs.

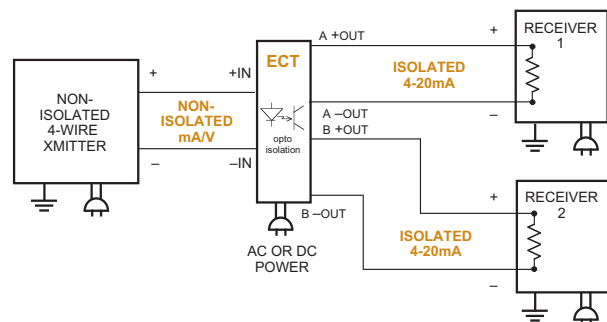
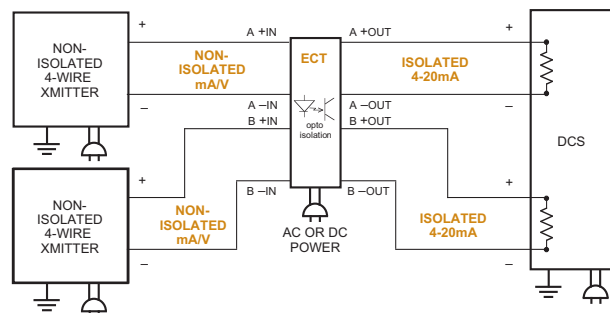

Figure 12. The ECT takes two process inputs and delivers two completely isolated signal outputs.



NOTE: ONLY 16V TX EXCITATION PROVIDED ON 2X4-20MA DUAL INPUT MODEL

► Specifications for 4-Wire Line/Mains Powered Models

Performance

Accuracy: ±0.1% of span

Stability: ±0.2% of reading per year

Isolation: WITHOUT -RF

OPTION: 1500Vrms between input and output and power; WITH -RF OPTION: 500Vrms between input and output, 1500Vrms power terminals; DUAL I/O WITHOUT -RF OPTION: 1500Vrms

Output Response Time:

DC Input: 100msec, maximum to 99% of output; AC Input: 400msec, maximum, from 0-99% of output

DC Input Resistance: 50 ohms

Ripple: 10mV peak-to-peak maximum measured across 250 ohm resistor

Load Effect: 0.01% of span from 0-100% of rated output (current only)

Power Supply Rejection:

<0.05% of Span

Maximum Input Overrange: Current inputs, 250% of full scale DC Voltage inputs 150% of full scale

Burden: 1V maximum with 4-20mA input; 0.01V maximum with 0-5A input

Output Current Limiting: 25mA, typical; 30mA, maximum

Output Tracking: Assuming

4-20mA input and 4-20mA output; the isolator output will follow the input below 3mA when the input fails.

Ambient Conditions

Operating Range:

-40°C to +85°C

-40°F to +185°F

Storage Range:

-40°C to +85°C

(-40°F to +185°F)

Ambient Temperature Effect: ±0.007% of span/°C, typical; ±0.015% of span/°C, maximum

Relative Humidity:

0-95% non-condensing

RFI/EMI Protection: Less than ±0.1% of span error when tested at

10V/m@20-1000MHz WITH -RF OPTION:

Less than ±0.1% of span error when tested at 30V/m@20-1000MHz;

DUAL I/O WITHOUT -RF OPTION:

Output unaffected by more than ±0.5% of span@10V/M 20-1000MHz

Common Mode Rejection:

Exceeds 95dB@60Hz with a limit of 1500Vrms

Adjustments

Front panel pots

Span: ±10%

Zero: ±5%

(non-interactive when span is set first)

Weight

Single I/O Channel:

384g (13.7 oz)

Dual I/O Channels:

431g (15.4 oz)

► Ordering Information

UNIT	INPUT	OUTPUT	POWER	OPTIONS	HOUSING
ECT 4-Wire (Line/ Mains) Powered Isolator/ Converter	SINGLE INPUT CHANNEL: 4-20MA into 50 ohms 1-5V into 1 Mohm 0-10V into 1 Mohm 0-150AC into 100 kohms 0-5AAC into 0.002 ohms DUAL INPUT CHANNELS: 2X4-20MA into 25 ohms 2x1-5V into 1 Mohm 2X0-10V into 1 Mohm (Other AC ranges also available)	SINGLE OUTPUT CHANNEL: 4-20MA into 1000 ohms 4-20MAB* See bi-directional note below 0-10V into 5 kohms minimum DUAL OUTPUT CHANNELS: 600 ohms 2X1-5V into 5 kohms minimum 2X0-10V into 5 kohms minimum SIGNAL SPLITTER DUAL OUTPUT CHANNELS: 2X4-20MA into 600 ohms (available with 4-20mA input only)	24DC , ±10% 117AC , 50/60Hz, ±10% 230AC , 50/60Hz, ±10% (3 watts maximum for single channel models; 5 watts maximum for dual output channel models) 12DC (9-16Vdc)	-DI Differential input. Performs A-B subtraction of two inputs where input A will always be larger than input B. The 4-20mA output will equal 0-100% difference between A and B inputs.* -EM Externally-mounted input transformer for current input (available with 0-5AAC input only) -EP External power, output stage powered by external source (only available on signal splitter in DIN housing) -RF Enhanced RFI/EMI filtering provides 30V/m@ 20-1000MHz protection with less than ±0.1% of span error (Not available on Dual Input Channel models) -TX 24V transmitter excitation (16V for 2X4-20MA DUAL INPUT model) for powering a 2-wire transmitter (available on 4-20mA input models only; standard on models with 2X4-20mA output) -VTD Standard Factory Calibration with NIST Test Data Report	DIN Aluminum DIN-style housing mounts on 32mm G-type (EN50035) and 35mm Top Hat (EN50022) rails FLB2 Externally-mounted flange provides a secure mount and ensures resistance to vibration

When ordering, specify: Unit / Input / Output / Power / Options [Housing]

Model number example: ECT / 1-5V / 4-20MA / 117AC / -RF [DIN]

**If input A is not always larger than input B, the ECT will provide a bi-directional 4-20mA output. The 4-20mA output will be 12mA when A=B, 20mA when input A is 100% and input B is 0%, and 4mA when input B is 100% and input A is 0%. In this case the output designation in the model number should be identified as 4-20mAB, denoting bi-directional output.*

ECT-DIN

Signal Isolator, Converter, Repeater, Booster and Splitter

Figure 13. Dimensions for 2-wire and 4-wire ECT-DIN models.

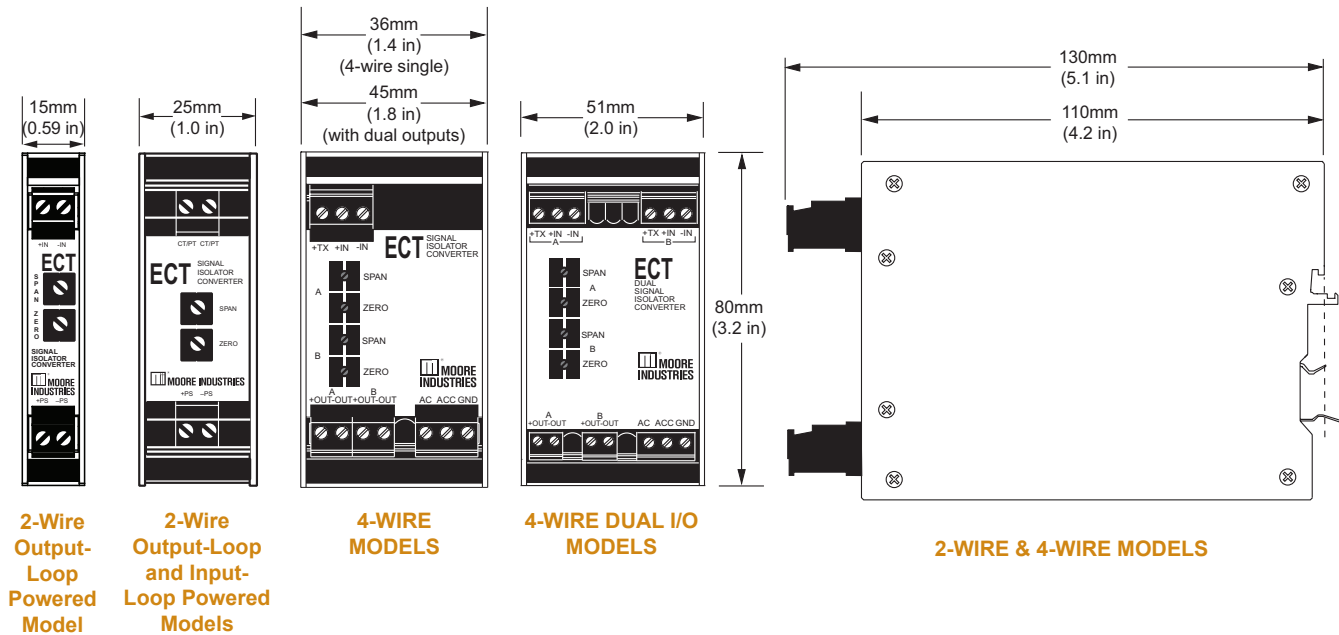

Table 1. Terminal Designations for 2-wire Units

2-Wire Output-Loop Powered Models	Top Terminals (left to right)		Bottom Terminals (left to right)	
	Output-Loop Powered	+IN	-IN	+PS
Output-Loop Powered with -EM Option	CT/PT	CT/PT	+PS	-PS
2-Wire Input-Loop Powered Model		Top Terminals (left to right)		
Input-Loop Powered	+IN	-IN	+OUT	-OUT

Table 4. Key to Table Abbreviations

Key	Definition
A	Channel 1 on dual output models
B	Channel 2 on dual output models
AC	AC line power input
ACC	AC line power return (neutral)
CT/PT	Current Transformer/Potential Transformer input
DC	+DC power input
DCC	-DC power input
GND	Ground
IN	Input signal (+ or -)
OUT	Output signal (+ or -)
-TX	Transmitter excitation for powering 2-wire transmitter

Table 2. Terminal Designations for 4-wire Units

4-Wire (Line/Mains-Powered) Models	Top Terminals (left to right)			Bottom Terminals (left to right)							
	T1	T2	T3	B1	B2	B3	B4	B5	B6	B7	B8
AC Power Single Input/Dual Outputs & -TX	+TX	+IN	-IN	A +OUT	A -OUT	B +OUT	B -OUT		AC	ACC	GND
DC Power Single Input/Dual Outputs & -TX	+TX	+IN	-IN	A +OUT	A -OUT	B +OUT	B -OUT		DC	DCC	GND
	T1	T2	T3	B1	B2	B3	B4	B5	B6		
Power with AC Inputs or -EM Option		CT/PT	CT/PT	+OUT	-OUT		AC	ACC	GND		
AC Power with -TX Option	+TX	+IN	-IN	+OUT	-OUT		AC	ACC	GND		
Power with DC Inputs or -EM Option		CT/PT	CT/PT	+OUT	-OUT		DC	DCC	GND		
DC Power with -TX Option	+TX	+IN	-IN	+OUT	-OUT		DC	DCC	GND		

Table 3. Terminal Designations for 4-wire Dual I/O Units

4-Wire (Line/Mains-Powered) Dual I/O Models	Top Terminals (left to right)									Bottom Terminals (left to right)								
	T1	T2	T3	T4	T5	T6	T7	T8	T9	B1	B2	B3	B4	B5	B6	B7	B8	B9
AC Power & Dual Inputs/Dual Outputs	A +TX	A +IN	A -IN				B +TX	B +IN	B -IN	A +OUT	A -OUT		B +OUT	B -OUT		AC	ACC	GND
DC Power & Dual Inputs/Dual Outputs	A +TX	A +IN	A -IN				B +TX	B +IN	B -IN	A +OUT	A -OUT		B +OUT	B -OUT		DC	DCC	GND



United States • info@miinet.com
Tel: (818) 894-7111 • FAX: (818) 891-2816
Australia • sales@mooreind.com.au
Tel: (02) 8536-7200 • FAX: (02) 9525-7296

Demand Moore Reliability

www.miinet.com

BeNeLux • info@mooreind.eu
Tel: 03/448.10.18 • FAX: 03/440.17.97

China • sales@mooreind.sh.cn
Tel: 86-21-62491499 • FAX: 86-21-62490635
United Kingdom • sales@mooreind.com
Tel: 01293 514488 • FAX: 01293 536852

Specifications and information subject to change without notice. Printed in the U.S.A.